

VISTA VALIDA PER LA STAMPA DELLA DIMA

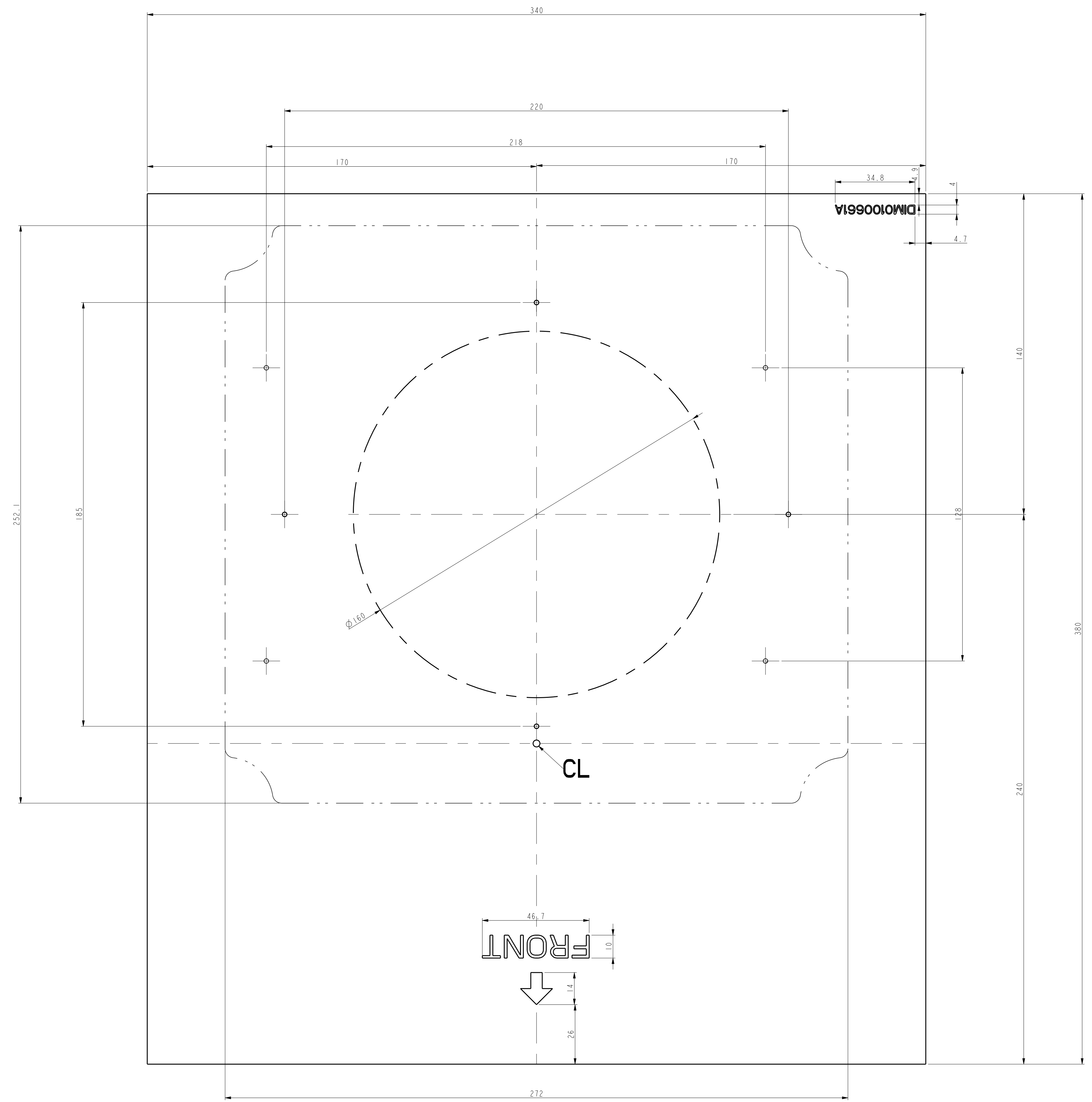

VISTA VALIDA PER LA VERIFICA DIMENSIONALE DELLA DIMA

DIM0100661 A	Cap 1 a 70 Gr/mq
MODEL CODE	MATERIAL

Conforme alla Direttiva 2002/95/EC (RoHS) Compliant with Directive 2002/95/EC (RoHS)			
MODEL	YE	DRW NO.	DIM0100661
SCALE	1:1		
DATE	15.05.14		
DESIGNER	PATERNIANI		
REVISION	1		
DATE	15.05.14		
DRW BY	PATERNIANI		



MODEL CODE: DIM0100661 A | MATERIAL: Cap 1 a 70 Gr/mq | DATE: 15.05.14 | DESIGNER: PATERNIANI | REVISION: 1 | SCALE: 1:1 | DRW NO.: DIM0100661 | MODEL: YE | CONFORME ALLA DIRETTIVA 2002/95/EC (RoHS) | COMPLIANT WITH DIRECTIVE 2002/95/EC (RoHS) | E-LICA S.P.A. | VIA S. GIUSEPPE, 10 | 40014 BOLOGNA (BO) | ITALY | TEL: +39 051 261111 | FAX: +39 051 261122 | WWW.ELICA.COM